

LED DISPLAY DRIVER

- 2 DIGIT LED DRIVER (14 segments)
- CURRENT GENERATOR OUTPUTS (no resistor required)
- CONTINUOUS BRIGHTNESS CONTROL
- SERIAL DATA INPUT
- DATA ENABLE
- WIDE SUPPLY VOLTAGE OPERATION
- TTL COMPATIBILITY

Applications Examples

- MICROPROCESSOR DISPLAYS
- INDUSTRIAL CONTROL INDICATOR
- RELAY DRIVER
- INSTRUMENTATION READOUTS

DESCRIPTION

The M5481 is a monolithic MOS integrated circuit produced with a N-channel silicon gate technology. It utilizes the M5450 die packaged in a 20-pin plastic package copper frame, making it ideal for a 2- digit display. A single pin controls the LED display brightness by setting a reference current through a variable resistor connected either to V_{DD} or to a separate supply of 13.2V maximum. The M5481 is a pin-to-pin replacement of the NS MM 5481.

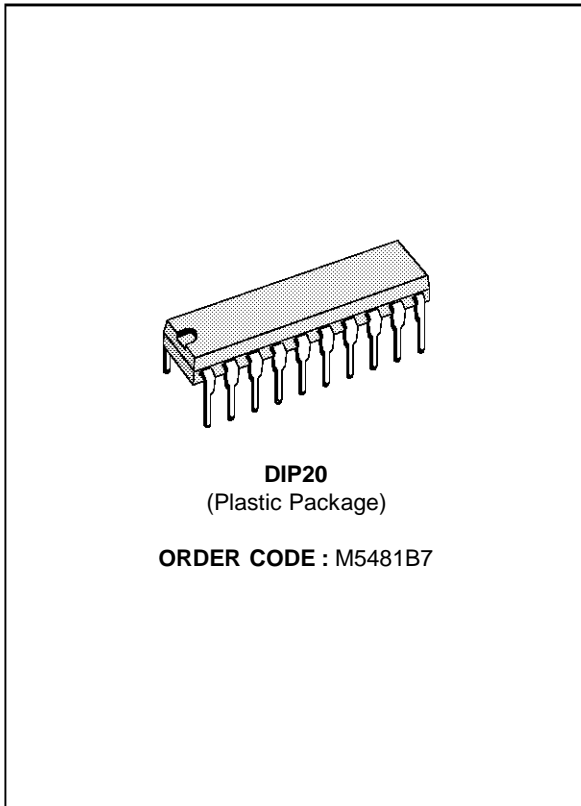

PIN CONNECTIONS

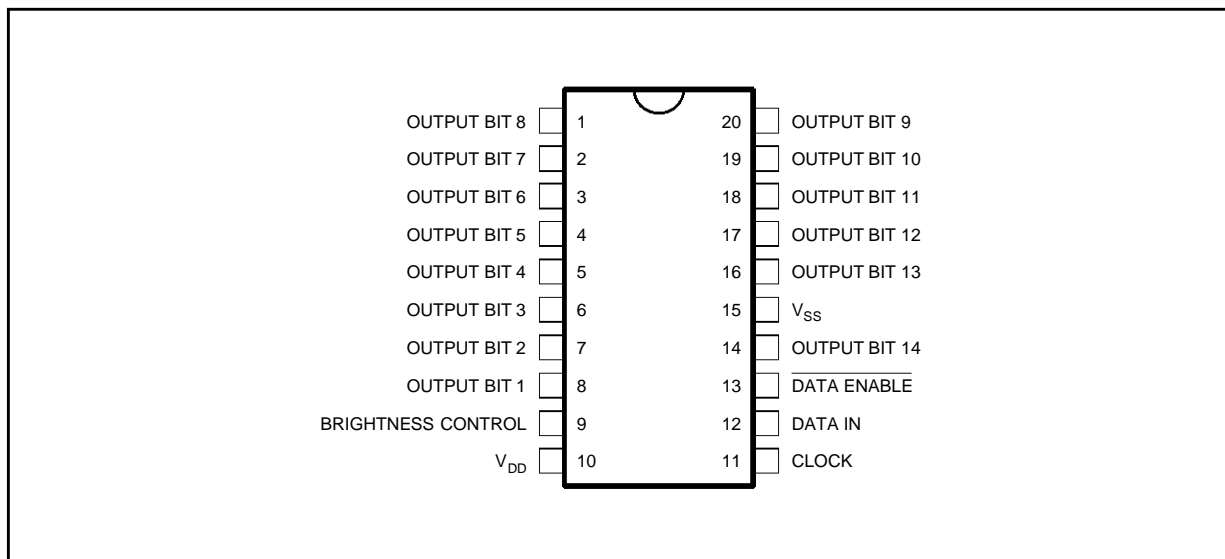

5481-01.EPS

BLOCK DIAGRAM

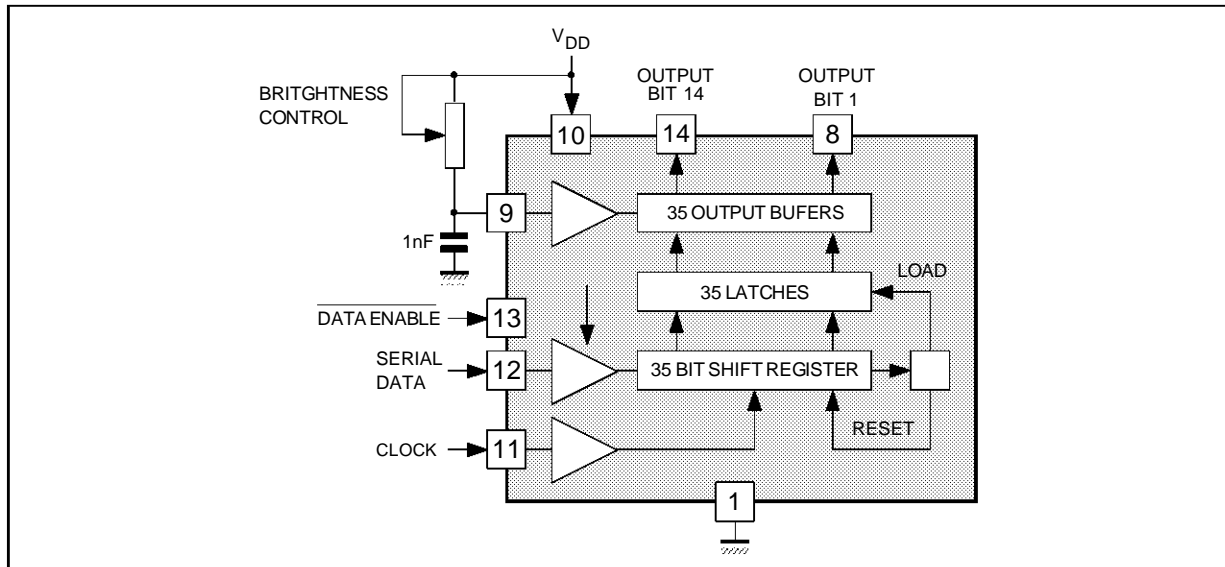

5481-02.EPS

ABSOLUTE MAXIMUM RATINGS

Symbol	Parameter	Value	Unit
V_{DD}	Supply Voltage	- 0.3 to 15	V
V_I	Input Voltage	- 0.3 to 15	V
$V_{O (off)}$	Off State Output Voltage	15	V
I_O	Output Sink Current	40	mA
P_{tot}	Total Package Power Dissipation at 25 °C at 85 °C	1.5 800	W mW
T_j	Junction Temperature	150	°C
T_{oper}	Operating Temperature Range	- 25, + 85	°C
T_{stg}	Storage Temperature Range	- 65, + 150	°C

5481-01.TBL

Stresses in excess of those listed under "Absolute Maximum Ratings" may cause permanent damage to the device. This is a stress rating only and functional operation of the device at these or any other conditions in excess of those indicated in the operational sections of this specification is not implied. Exposure to absolute maximum rating conditions for extended periods may affect device reliability.

STATIC ELECTRICAL CHARACTERISTICS(T_{amb} within operating range, V_{DD} = 4.75V to 13.2V, V_{SS} = 0V, unless otherwise specified)

Symbol	Parameter	Test Conditions	Min.	Typ.	Max.	Unit
V _{DD}	Supply Voltage		4.75		13.2	V
I _{DD}	Supply Current	V _{DD} = 13.2 V			7	mA
V _I	Input Voltages Logical "0" Level Logical "1" Level	± 10 μA Input Bias 4.75 ≤ V _{DD} ≤ 5.25 V _{DD} > 5.25	-0.3 2.2 V _{DD} - 2		0.8 V _{DD} V _{DD}	V V V
I _B	Brightness Input Current (note 2)		0		0.75	mA
V _B	Brightness Input Voltage (pin 9)	Input Current = 750 μA T _{amb} = 25°C	3		4.3	V
V _{O(off)}	Off State Output Voltage				13.2	V
I _O	Output Sink Current (note 3) Segment OFF Segment ON	V _O = 3 V V _O = 1 V (note 4) Brightness In. = 0 μA Brightness In. = 100 μA Brightness In. = 750 μA	0 2 12	2.7 15	10 10 25	μA μA mA mA
f _{clock}	Input Clock Frequency		0		0.5	MHz
I _O	Output Matching (note 1)				± 20	%

- Notes :**
1. Output matching is calculated as the percent variation from I_{MAX} + I_{MIN}/2.
 2. With a fixed resistor on the brightness input some variation in brightness will occur from one device to another.
 3. Absolute maximum for each output should be limited to 40 mA.
 4. The V_O voltage should be regulated by the user.

FUNCTIONAL DESCRIPTION

The M5481 uses the M5450 die which is packaged to operate 2-digit alphanumeric displays with minimal interface with the display and the data source. Serial data transfer from the data source to the display driver is accomplished with 2 signals, serial data and clock. Using a format of a leading "1" followed by the 35 data bits allows data transfer without an additional load signal.

The 35 data bits are latched after the 36th bit is complete, thus providing non-multiplexed, direct drive to the display. Outputs change only if the serial data bits differ from the previous time. Display brightness is determined by control of the output

current for LED displays. A 1nF capacitor should be connected to brightness control, Pin 9, to prevent possible oscillations.

A block diagram is shown in Figure 1. The output current is typically 20 times greater than the current into Pin 9, which is set by an external variable resistor.

These is an internal limiting resistor of 400 Ω nominal value.

Figure 2 shows the input data format. A start bit of logical "1" precedes the 35 bits of data. At the 36th clock a LOAD signal is generated synchronously with the high state of the clock, which loads the 35 bits of the shift registers into the latches.

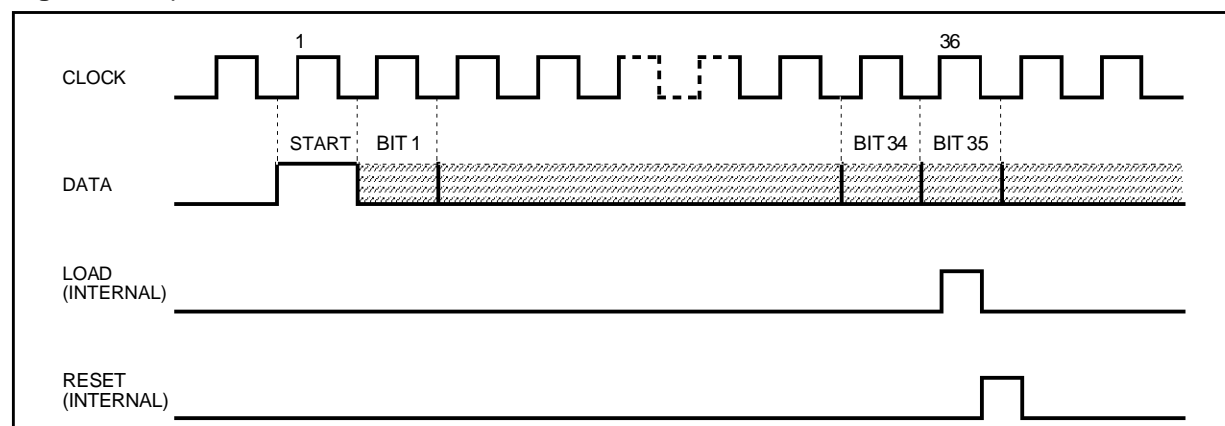
Figure 2 : Input Data Format

M5481

At the low state of the clock a RESET signal is generated which clears all the shift registers for the next set of data. The shift registers are static master slave configurations. There is no clear for the master portion of the first shift register, thus allowing continuous operation.

There must be a complete set of 36 clocks or the shift registers will not clear.

When power is first applied to the chip an internal power ON reset signal is generated which resets all registers and all latches. The START bit and the first clock return the chip to its normal operation.

Figure 3 shows the timing relationships between Data, Clock and DATA ENABLE.

A maximum clock frequency of 0.5 MHz is assumed.

Figure 4 shows the Output Data Format for the M5481. Because it uses only 14 of the possible 35 outputs, 21 of the bits are "Don't Cares".

For applications where a lesser number of outputs are used it is possible to either increase the current per output or operate the part at higher than 1V V_{OUT} .

The following equation can be used for calculations.

$$T_j = [(V_{OUT})(I_{LED})(\text{No. of segments}) + V_{DD} \cdot 7 \text{ mA}] (80 \text{ }^\circ\text{C/W}) + T_{amb}$$

where:

T_j = junction temperature (150 °C max)

V_{OUT} = the voltage at the LED driver outputs

I_{LED} = the LED current

80 °C/W = thermal coefficient of the package

T_{amb} = ambient temperature

Figure 3

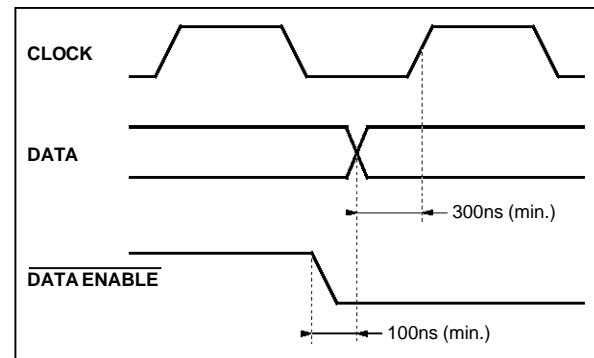

5481-04.EPS

Figure 4 : Serial Bus / Outputs Correspondance

5450	34	33	32	31	30	29	28	27	26	25	24	23	22	21	20	19	18	START
5481	X	X	X	X	14	13	X	X	X	X	12	11	10	9	X	X	X	START

5450	17	16	15	14	13	12	11	10	9	8	7	6	5	4	3	2	1	START
5481	X	8	7	6	5	X	X	X	X	4	3	2	1	X	X	X	X	START

5481-03.TBL

TYPICAL APPLICATION

BASIC electronically tuned TV system.

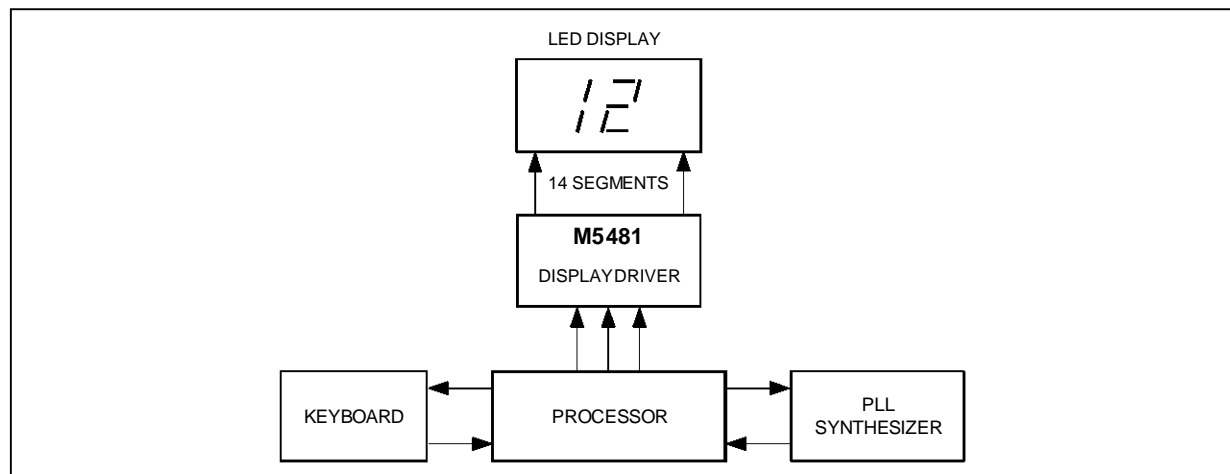

5481-06.EPS

POWER DISSIPATION OF THE IC

The power dissipation of the IC can be limited using different configurations.

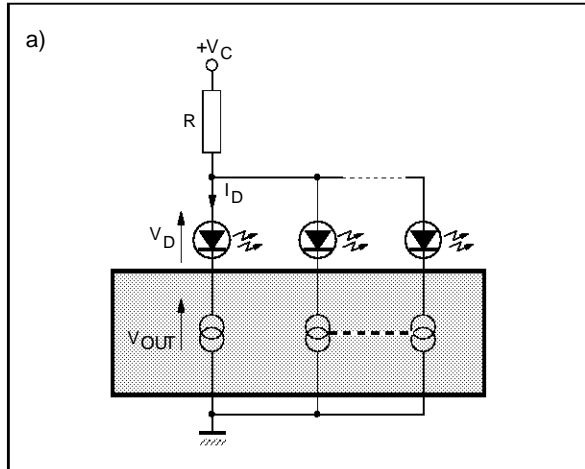

In this application R must be chosen taking into account the worst operating conditions.

R is determined by the maximum number of segments activated.

$$R = \frac{V_C - V_{D\text{ MAX}} - V_{O\text{ MIN}}}{N_{\text{MAX}} \cdot I_D}$$

The worst case condition for the device is when roughly half of the maximum number of segments are activated.

It must be checked that the total power dissipation does not exceed the absolute maximum ratings of the device.

In critical cases more resistors can be used in conjunction with groups of segments. In this case the current variation in the single resistor is reduced and P_{tot} limited.

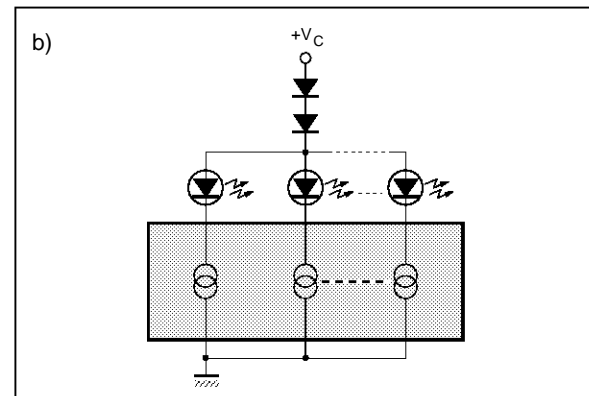

In this configuration the drop on the serial connected diodes is quite stable if the diodes are properly chosen.

The total power dissipation of the IC is, in first approximation, depending only on the number of segments activated.

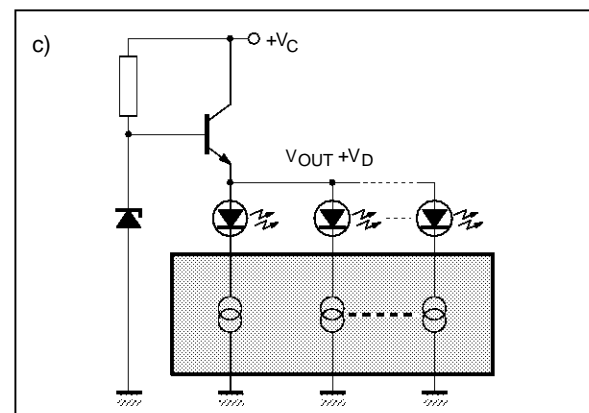

In this configuration $V_{\text{OUT}} + V_D$ is constant. The total power dissipation of the IC depends only on the number of segments activated.

PACKAGE MECHANICAL DATA

20 PINS - PLASTIC DIP

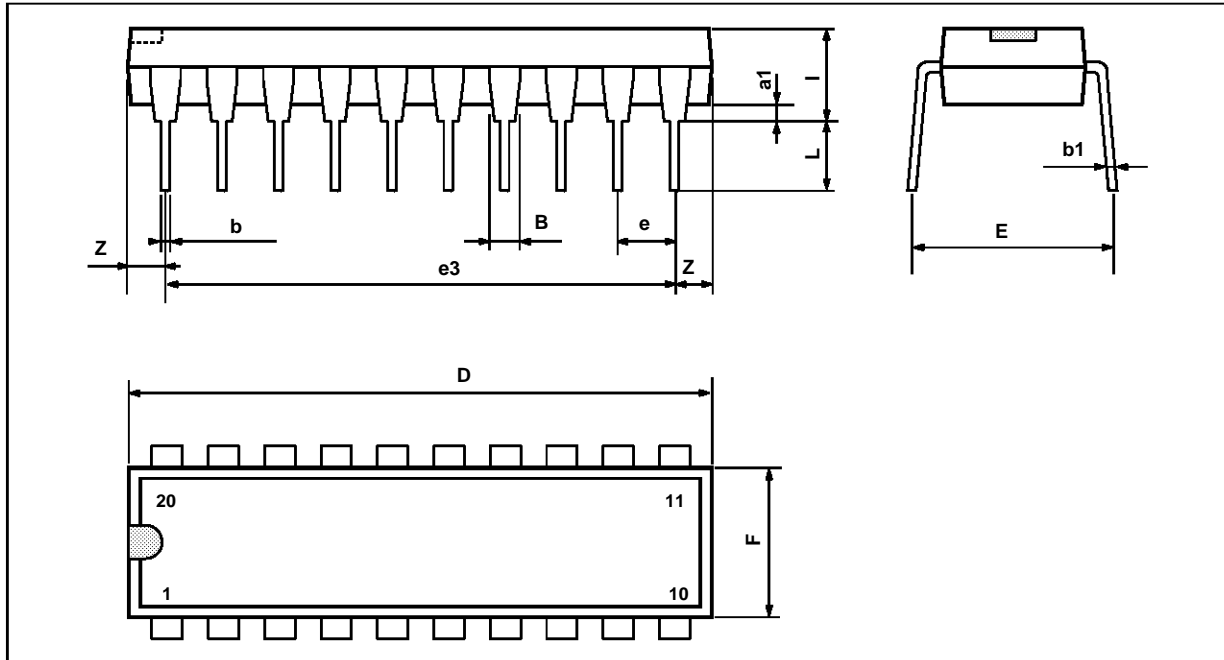

PH-DIP20.EPS

Dimensions	Millimeters			Inches		
	Min.	Typ.	Max.	Min.	Typ.	Max.
a1	0.254			0.010		
B	1.39		1.65	0.055		0.065
b		0.45			0.018	
b1		0.25			0.010	
D			25.4			1.000
E		8.5			0.335	
e		2.54			0.100	
e3		22.86			0.900	
F			7.1			0.280
i			3.93			0.155
L		3.3			0.130	
Z			1.34			0.053

DIP20.TEL

Information furnished is believed to be accurate and reliable. However, SGS-THOMSON Microelectronics assumes no responsibility for the consequences of use of such information nor for any infringement of patents or other rights of third parties which may result from its use. No licence is granted by implication or otherwise under any patent or patent rights of SGS-THOMSON Microelectronics. Specifications mentioned in this publication are subject to change without notice. This publication supersedes and replaces all information previously supplied. SGS-THOMSON Microelectronics products are not authorized for use as critical components in life support devices or systems without express written approval of SGS-THOMSON Microelectronics.

© 1994 SGS-THOMSON Microelectronics - All Rights Reserved

Purchase of I²C Components of SGS-THOMSON Microelectronics, conveys a license under the Philips I²C Patent. Rights to use these components in a I²C system, is granted provided that the system conforms to the I²C Standard Specifications as defined by Philips.

SGS-THOMSON Microelectronics GROUP OF COMPANIES

Australia - Brazil - China - France - Germany - Hong Kong - Italy - Japan - Korea - Malaysia - Malta - Morocco
The Netherlands - Singapore - Spain - Sweden - Switzerland - Taiwan - Thailand - United Kingdom - U.S.A.